

Radial Engine Assembly

In this project, you will create the Radial Engine assembly shown in Figures 1 and 2. The Radial Engine assembly will be created in two parts, one will be the subassembly and the other will be the main assembly. The dimensions of the components of the Radial Engine assembly are shown in Figures 3 through 6.

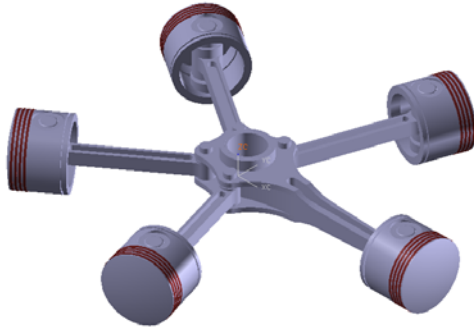

Figure 1 The Radial Engine assembly



Figure 2 The exploded view of the assembly

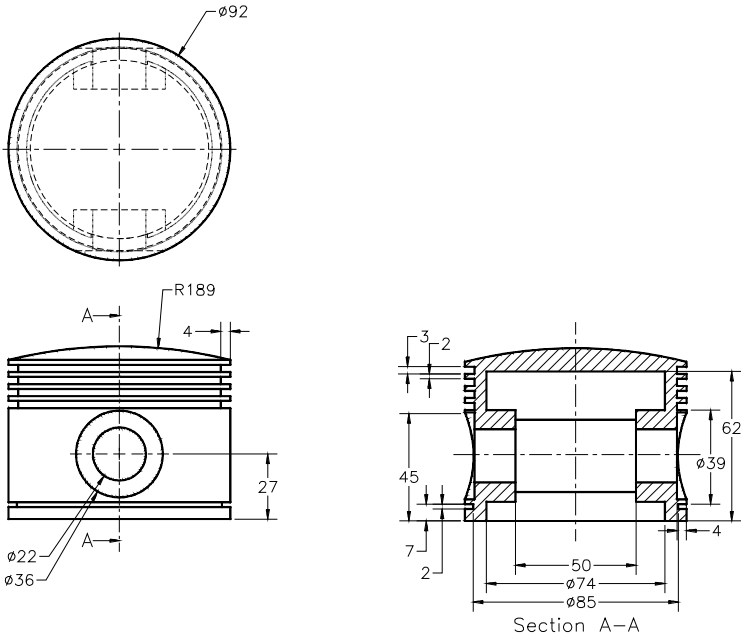

Figure 3 Views and dimensions of the Piston

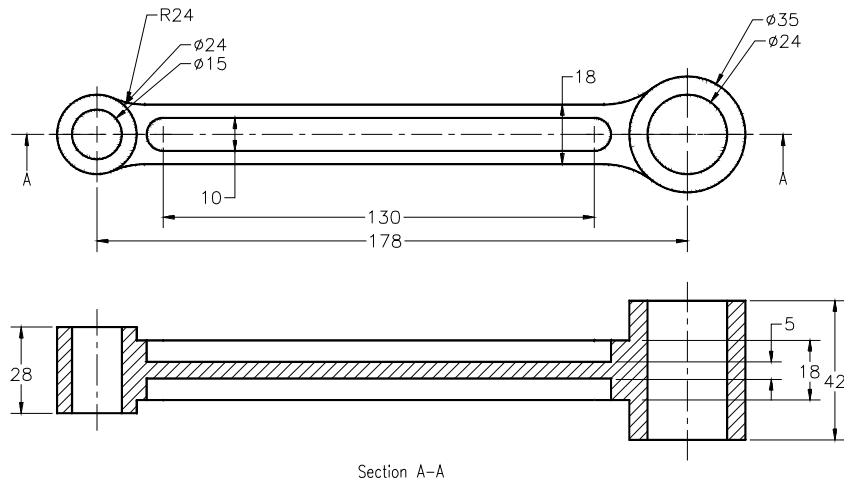

Figure 4 Views and dimensions of the Articulated Rod

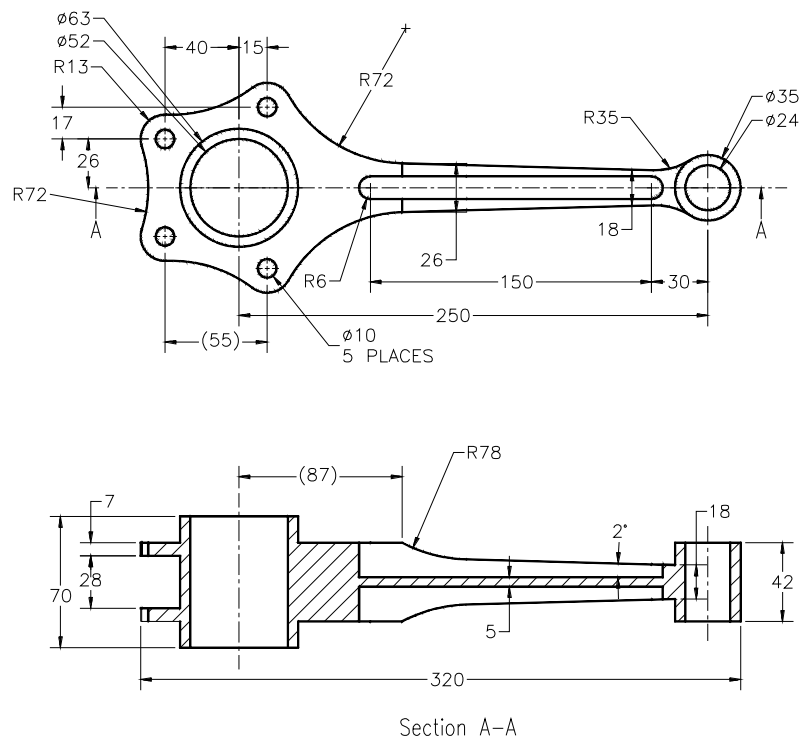

Figure 5 Views and dimensions of the Master Rod

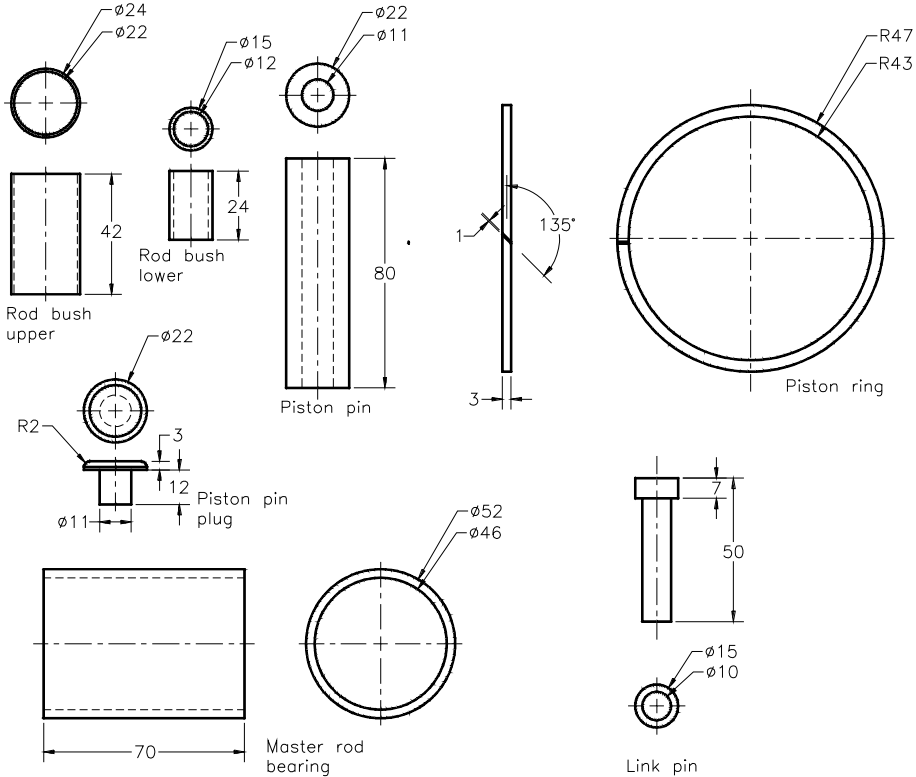

Figure 6 Views and dimensions of the Rod Bush Upper, Rod Bush Lower, Piston Pin Plug, Piston Pin, Piston Rings, and Master Rod Bearing